

# Discrete Maths - Digital Logic

## Laboratory 4: Parallel Addition and Subtraction

2007 September 14 edition

### Equipment List

1. 5V power supply
2. Protoboard
3. Switch and LED board
4. Cutters
5. Pliers
6. Single strand hook-up wire
7. One 74LS04 (hex INVERTER)
8. One 74LS283 (4-bit Adder)

### 1 Four-bit Adder

The **74LS283** is a **4-bit adder** (equivalent to cascading four Full Adders). Here is its **pinout diagram**, labelled with the least significant bit (LSB) as **bit zero (0)**. *Notice that it has **sixteen (16) pins***, unlike the fourteen pin chips that you have become accustomed to.

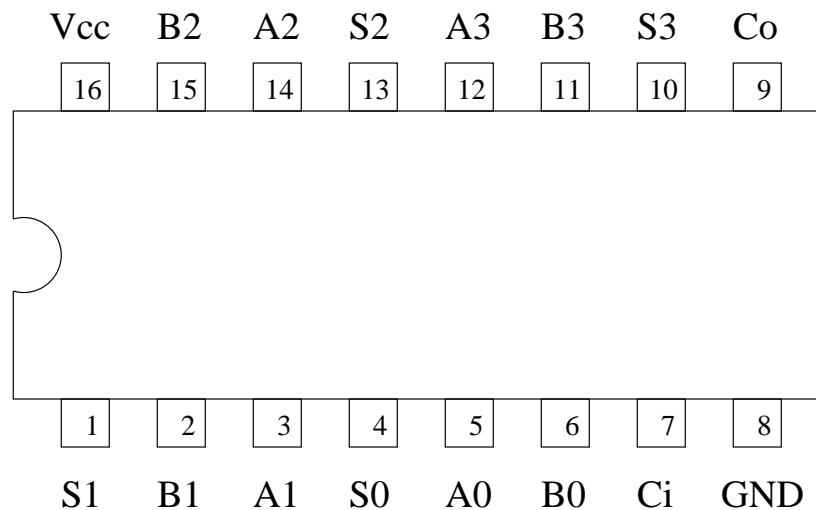

**Table of recommended Colors, Switches and LEDs:**

Pin	Signal	Bit Value	Color	Switch	LED
1	S1	1	Orange	None	2
2	B1	1	Orange	2	None
3	A1	1	Orange	6	None
4	S0	0	Brown	None	1
5	A0	0	Brown	5	None
6	B0	0	Brown	1	None
7	Ci	0	Brown	Toggle	None
8	GND	None	Black	None	None
9	Co	4	Blue	None	5
10	S3	3	Green	None	4
11	B3	3	Green	4	None
12	A3	3	Green	8	None
13	S2	2	Yellow	None	3
14	A2	2	Yellow	7	None
15	B2	2	Yellow	3	None
16	Vcc	None	Red	None	None

If any switch is blocked, you can instead connect the input pin by wire to GND (logic 0) or VCC (logic 1) as needed.

**BUILD the four-bit adder circuit, and KEEP it: you will use it throughout this session, with minor modifications.**

**Now TEST the four-bit adder, and record your observed results in the following table.** (The second row identifies the switches and LEDs, to help in recording the results accurately.)

$A_3$	$A_2$	$A_1$	$A_0$	$B_3$	$B_2$	$B_1$	$B_0$	$C_i$	$C_o$	$S_3$	$S_2$	$S_1$	$S_0$
8	7	6	5	4	3	2	1	T	5	4	3	2	1
0	0	0	0	0	0	0	0	0					
0	0	0	0	0	0	0	0	1					
0	0	0	0	0	0	0	1	0					
0	0	0	0	0	0	1	0	0					
0	0	0	0	0	1	0	0	0					
0	0	0	1	0	0	0	0	0					
0	0	1	0	0	0	0	0	0					
0	1	0	0	0	0	0	0	0					
1	0	0	0	0	0	0	0	0					
0	0	0	1	0	0	0	1	0					
0	0	1	0	0	0	1	0	0					
0	1	0	0	0	0	1	0	0					
1	0	0	0	1	0	0	0	0					
0	0	0	1	0	0	0	1	1					
1	1	1	1	1	1	1	1	1					

## 2 Negative Binary Numbers

### 2.1 Table of Two's Complement 4 Bit Numbers

The **one's complement** of a binary number is obtained by **inverting** all its bits. The *negative* of a binary number is usually represented by its **two's complement**, which is obtained by **adding 1** to its one's complement. That is,  $-D = \overline{D} + 1$ . For example,  $-2 = \overline{2} + 1 = \overline{0010} + 1 = 1101 + 1 = 1110$ .

Here's **how to check** a **2's complement** calculation. If you add a number to its one's complement, you get the binary number with all of its bits equal to **1**. Therefore if you **add a number to its two's complement**, the result is all **zeros**, except for a **carry out** of **1**. For example,  $-2 + 2 = 1110 + 0010 = 10000$ .

**Complete the following table for the binary representations of all signed 4 bit numbers.**

Number	A3	A2	A1	A0
7	0	1	1	1
6				
5				
4				
3				
2				
1				
0	0	0	0	0
-1				
-2	1	1	1	0
-3				
-4				
-5				
-6				
-7				
-8	1	0	0	0

### 2.2 Design of 4 Bit Negation Circuit

The **logic symbol** for the 74LS283 is as follows.

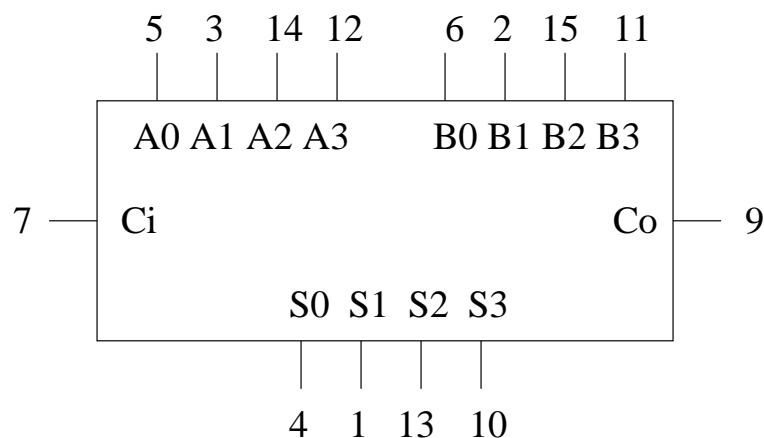

$V_{cc} = \text{pin } 16$   
 $GND = \text{pin } 8$

Using a **74LS04** hex inverter IC and a **74LS283**, you can design a logic circuit to perform a **4 bit two's complement**.

Let's separate the wires connecting **switches 1 to 4** from the **B** pins, and connect those wires instead to the inputs of **4 inverters**. These wires will now carry a new 4-bit quantity **D** comprising signals  $D_3$  to  $D_0$ . The outputs of the inverters equal its **one's complement**  $\bar{D}$ .

Since the two's complement  $-D$  is given by the formula  $-D = \bar{D} + 1$ , we can produce  $-D$  by **tying 74LS283 input  $C_i$  to logic 1** (the 5V rail), **wiring  $\bar{D}$  (the outputs of the inverters) to 74LS283 inputs  $B$**  (with consistent colors), and **keeping the  $A$  inputs (switches 8 to 5) at logic 0**.

**Here is a design for the 4 bit negator/subtractor: Not that it includes all pin numbers, signal colors, and all switch and LED numbers.**

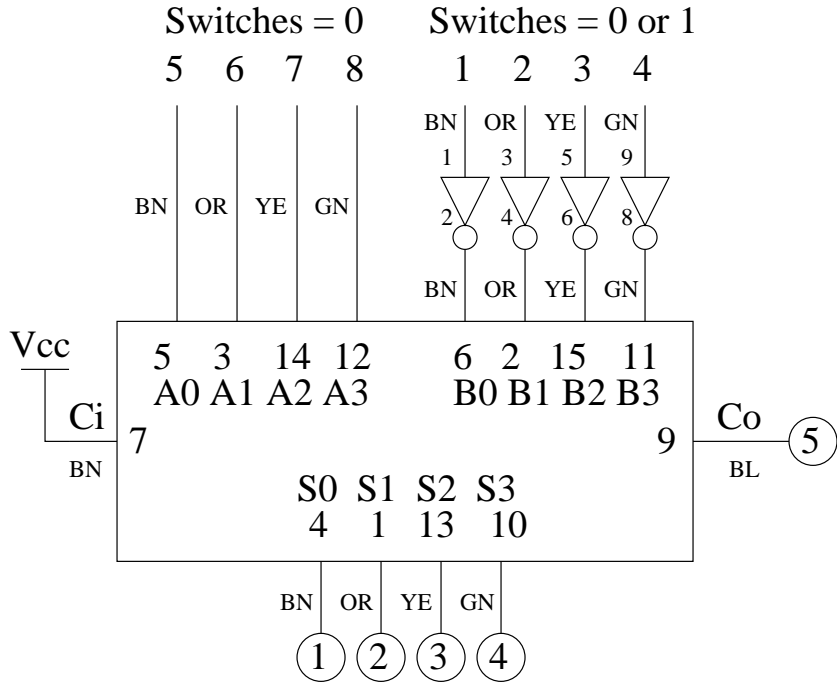

### 2.3 Construction of 4 Bit Negation Circuit

Make the few small required changes to the  $A$ ,  $B$  and  $C_i$  connections to **implement** the design.

**Have a demonstrator check your construction.**

Only then **test** the circuit, recording your observations in this table for  $S = -D$ .

D3	D2	D1	D0	$C_o$	S3	S2	S1	S0
4	3	2	1	5	4	3	2	1
0	0	0	0					
0	0	0	1					
0	0	1	0					
0	0	1	1					
0	1	0	0					
0	1	0	1					
0	1	1	0					
0	1	1	1					
1	0	0	0					
1	0	0	1					
1	0	1	0					
1	0	1	1					
1	1	0	0					
1	1	0	1					
1	1	1	0					
1	1	1	1					

**DON'T pull anything apart! KEEP this circuit exactly as it is!**

### 3 Binary Subtraction

Since **subtraction**  $A - D$  is the **addition** of  $A$  **with** the **negative** of  $D$ , namely  $A + (-D)$ , we can use **one** 74LS283 IC and four 74LS04 inverters to perform a **four-bit binary subtraction**. In fact, we'll use the **same** circuit as the previous section.

**Test it, and record your observations in the next table for  $S = A - D$ .**

A3	A2	A1	A0	D3	D2	D1	D0	$C_o$	S3	S2	S1	S0
0	0	0	0	0	0	0	0					
1	1	1	1	1	1	1	1					
0	0	0	1	0	0	0	0					
0	0	0	0	0	0	0	1					
0	0	0	0	1	0	0	0					
0	0	0	0	1	1	1	1					
1	1	1	1	0	0	1	1					
1	1	1	1	1	1	0	0					
1	1	0	0	0	0	1	1					
0	1	0	1	1	0	1	0					

### 4 Clean Up

Please return every cord to the racks, every wire to the recycle bin, and the pliers, cutters and I/O boards to the front table. **Leave the ICs on the breadboard, and leave the breadboard on your bench.** Clean

the bench and the **carpet**, and have them **checked and signed-for by a demonstrator**. Place your chair under the bench, and **hand in your completion sheet**.

Geoffrey Tobin