

Question 1.

1. What are the *symbol* and *name* for the metric prefix meaning ten to the power of twenty-one (21)?
2. What is the *symbol* and *name* for the metric unit for **conductance**? (Hint: it's named after a founder of a leading German electronics firm.)
3. Give an example each of a **direct**, an **indirect**, and a **null** measurement.
4. In analog to digital conversion, **quantization** occurs. Explain in what sense is this a source of measurement error?

Question 2.

1. What is the *advantage* of **null detection** for precision of measurement in bridge circuits?
2. *Draw* a **Wheatstone** bridge.
3. *Derive* the **null condition** for the Wheatstone bridge.
4. *Name* the kind of AC bridge suited to measuring a *wide* range of inductances?

Question 3.

1. *List six (6)* characteristics of an **ideal** op-amp.
2. *Define* **offset current**.
3. *Draw* an op-amp **differentiator**.
4. Give one situation in which an **isolation amplifier** is necessary.

Question 4.

1. What is the name given to the phenomenon whereby *mechanical deformation* causes changes in *electrical resistance*?
2. In *what kind* of temperature transducer does the **Peltier effect** occur?
3. As a displacement transducer, what is one *limitation* of the **Linear Variable Differential Transformer (LVDT)**?
4. When heavily reverse-biased, semiconductor pn junctions are **photoconductive**. What does this mean?

Question 5.

1. The 74LS163 counter has **synchronous presets** (CLR and LD). Exploit this to *design* a synchronous modulo-12 counter.

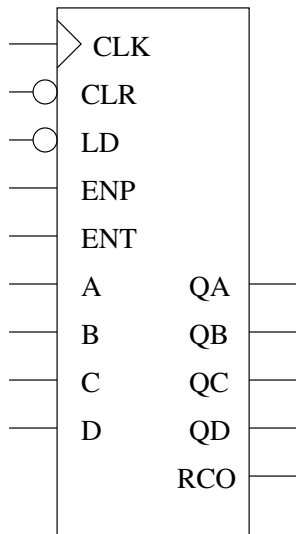

2. What does a **frequency counter** do?
3. If a 2 GHz oscillator has a *stability specification* of 10^{-10} , what is its **frequency error** in Hertz?
4. Compact discs store audio dynamic range (amplitude) information in a 16-bit digital representation. *Calculate* the **number of conversion steps** needed to quantize a *maximum amplitude* audio sample using a:
 - (a) Ramp ADC.
 - (b) Successive Approximation ADC.
 - (c) Flash ADC.

Question 6.

1. State the **Barkhausen criterion** for oscillation in a feedback amplifier.
2. Name one **audio**-frequency oscillator circuit.
3. Define **frequency modulation** (FM).
4. A *square wave* is input to an amplifier with **poor low-frequency response**.
 - (a) What is the effect at the output?
 - (b) *Sketch* the output waveform.

Question 7.

1. In a cathode ray oscilloscope (CRO), which *control knob* do you use to adjust the electrostatic lens?
2. What is the **graticule**?
3. What is **retrace**?
4. What is **blanking**?
5. Which *switch* do you use to control the **sweep rate**?
6. Give one (1) *advantage* and one (1) *disadvantage* of a **sampling oscilloscope**.

Question 8.

1. State one *advantage* of a **times-ten (10X)** probe over a times-one (1X) probe.
2. What is **flashover**?
3. Describe the operation of the **spectrum analyser** by reference to each block in the figure below.

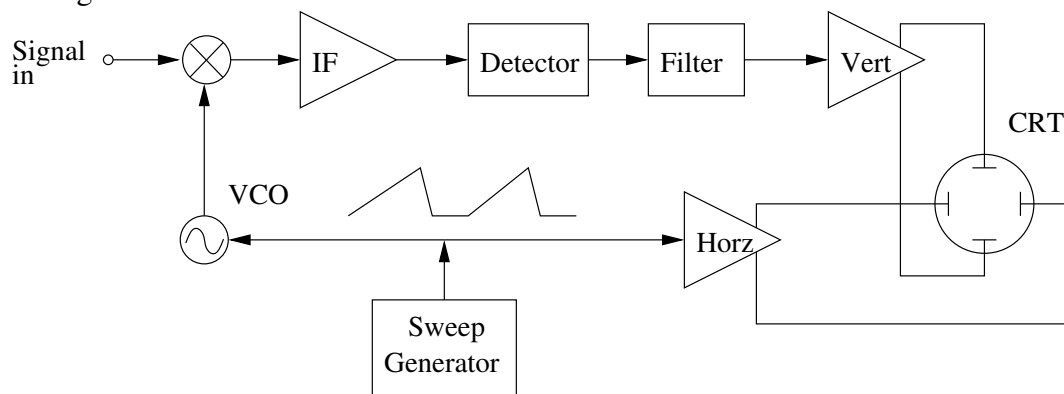

Question 9.

1. Define **total harmonic distortion**.
2. What is the definition of the **common mode rejection ratio (CMRR)**?
3. Define **quality factor**.
4. Describe the purpose of each block in the following diagram of a wideband sweep generator.

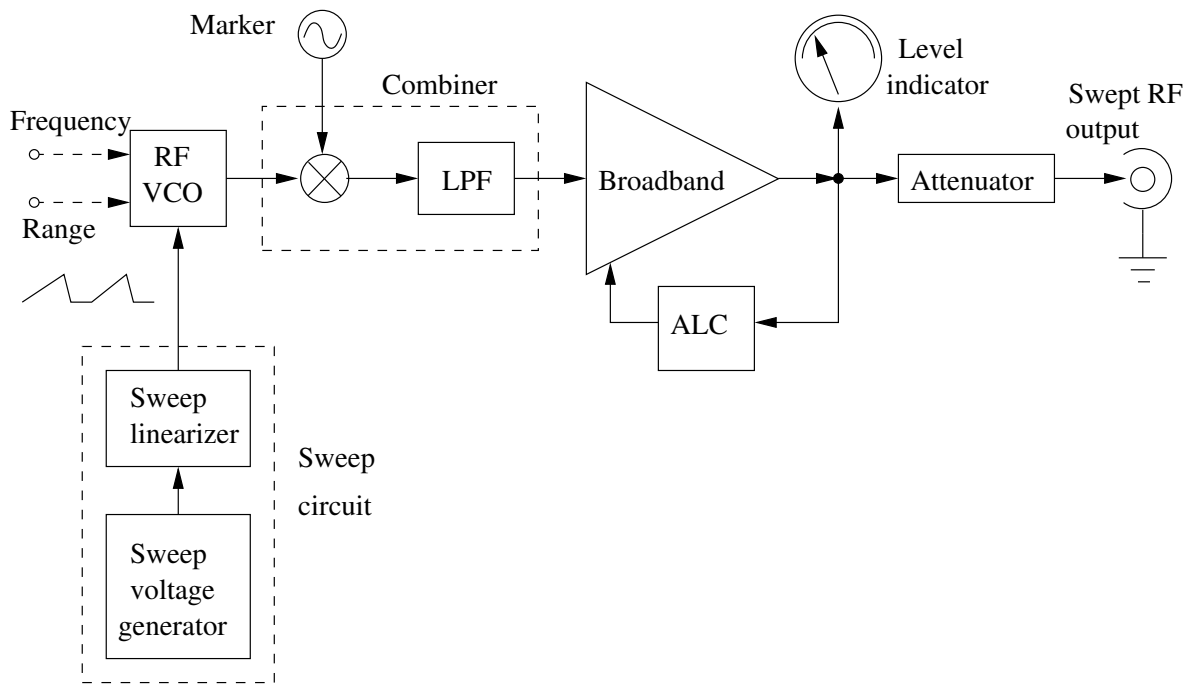

Question 10.

1. List six advantages of **Automatic Test Equipment** (ATE) over manual testing.
2. What are the two bus topologies allowed in the **General Purpose Interface Bus** (GPIB).
3. Name the two kinds of **pink** noise.
4. The RMS **shot noise** current (a kind of white noise) is given by: $i_{RMS} = \sqrt{2q_e I_{DC} \Delta f}$.
 - (a) What is the *cause* of shot noise?
 - (b) Define the **effective noise bandwidth** Δf .

Question 11.

1. List five (5) *sources* of **radio frequency** (RF) radiation.
2. *Name* the three (3) lines in the standard AC power cable.
3. Define **common mode noise voltage**.
4. What is an electromagnetic **shield**?
5. Why is it *difficult* to shield against **magnetic** fields?